

ONE ER32 H100

codice code **FL.ONE.00/100C63F-H1**

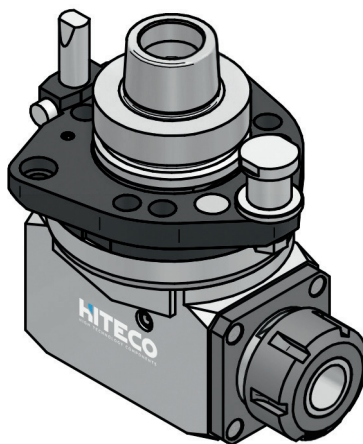

ONE ER32 H100

FL.ONE.00/100C63F-H1





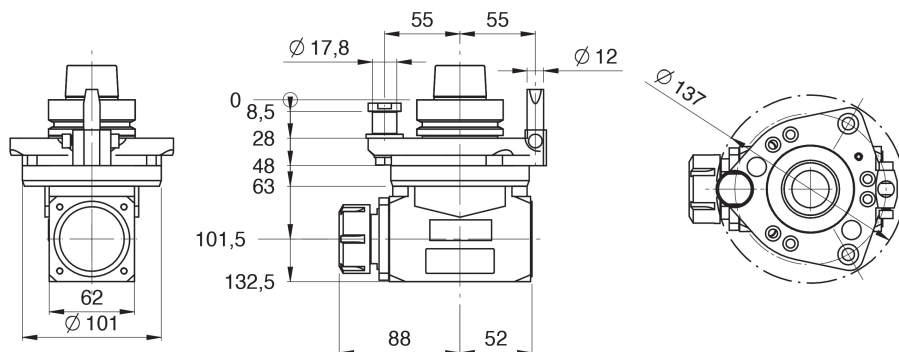









| | | |
|---|--------------|-----------------------------|
| Attacco mandrino Spindle coupling | | HSK 63F |
| Velocità max. rotazione mandrino Max spindle speed | giri/min rpm | 10850* |
| Velocità max. rotazione utensile Max tool speed | giri/min rpm | 15500* |
| Senso rotazione mandrino Spindle rotation direction | | vedi disegno see drawing |
| Possibilità inversione rotazione mandrino Possibility to change electrospindle direction | | NO |
| Rapporto di trasmissione Gear ratio | | 1:1.43 |
| Attacco utensile Tool coupling | | ER32DX |
| Diametro codolo Tool shank diameter | mm | 2 - 20 |
| Diametro lama Blade diameter | mm | - |
| Diametro foro lama Hole blade diameter | mm | - |
| Peso Weight | Kg | 4,2 |
| Lubrificazione Lubrication | | Grasso Grease |
| Temperatura max. Max temperature | °C/F | 75 / 167 |
| Orientamento angolare Aggregate rotation | | 0°/360° continuo continuous |
| Connessione asse C C axis connection type | | H1 |

* vedere manuale see user manual



CONFIGURABILITÀ CONFIGURABILITY

FL.ONE.00 WWW-X-YYY-ZZ

| ALTEZZA HEIGHT | WWW | |
|---|---------|--|
| 100 | 100 | |
| 145 | 145 | |
| 180 | 180 | |
| ATTACCO UTENSILE TOOL HOLDER | X | |
| ER32 | C | |
| ATTACCO MANDRINO SPINDLE INTERFACE | YYY | |
| HSK 63F | 63F |  |
| HSK 63E | 63E |  |
| ISO 30 | I30 |  |
| ISO 30 SCM* | I3S |  |
| RIFERIMENTI C AXIS CONNECTION | ZZ | |
| SCM HITECO 1 PIN | H1 |  |
| SCM 3 PIN - SCM 1 PIN - MORBIDELLI 3PIN - 1PIN | S3/(S1) |  |
| ISO 30 SCM* | SS* |  |
| BUSELLATO | BU |  |
| BIESSE | BI |  |
| CMS | CM |  |
| SCM 1 PIN OLD | D1 |  |
| SCM/HITECO 3 PIN (con ut. pneumatiche with air supplies) | H3 |  |
| SCM/MORBIDELLI 3 PIN (con ut. pneumatiche with air supplies) | SP |  |
| HOMAG (con ut. pneumatiche with air supplies) | HO |  |
| VARIE SUNDRY ITEMS | | |
| CHIP | CHIP | |

* I3S compatibile solo con SS I3S only compatible with SS