



SPINDLE

www.gpm-asia.com

CONTENTS

P1-2	主軸特點 Spindle Features
P3-4	SPM / 銑削主軸 Milling Spindle
P5-6	SPM / 研磨主軸 Grinding Spindle
P7-8	IMA / RTS / RGB 主軸 RTS / RGB Spindle
P9-10	TRAMEC / 單/雙臂 旋轉頭 Single / Double Arms Milling Head
P11-12	HITECO / 提供機床廠的生產解決方案 Provide Production Solutions for Machine Tool Manufactures
P17-18	公司發展歷程 Company Profile

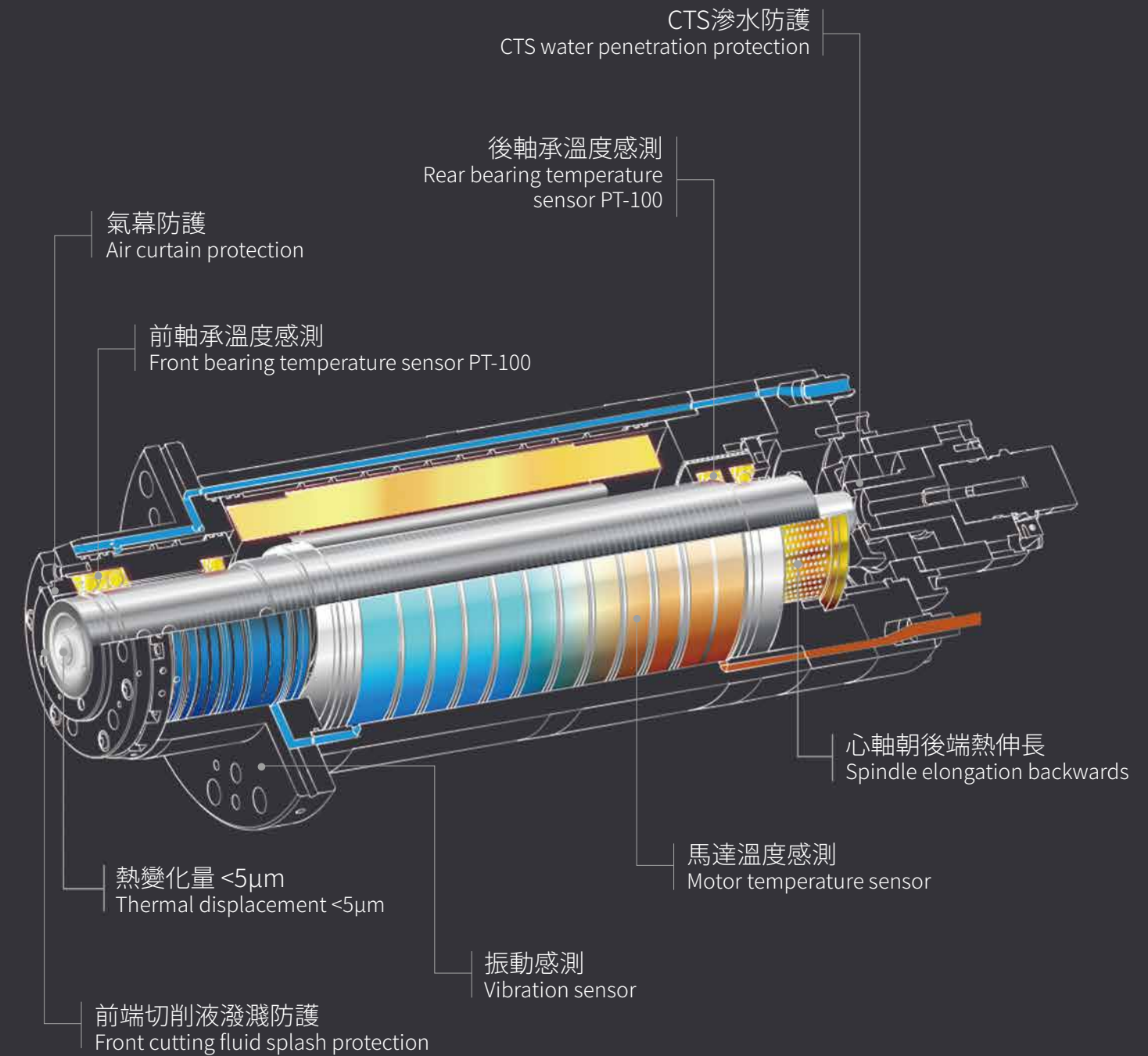
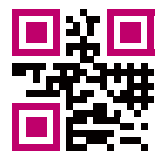

2D 動畫



SM 190



SM 230



產品型號 Product Model	SM 80	SM100	SM120	SM150	SM 170	SM 210	SM 230
主軸外徑 Spindle outer diameter	Ø 80	Ø 100	Ø 120	Ø 150	Ø 170	Ø 210	Ø 230
最高轉速 rpm Max Speed	油脂潤滑 Grease lubrication	40000	30000	30000	20000	18000	16000
	油氣潤滑 Oil-air lubrication	-	-	40000	24000	24000	24000
主軸電壓 Spindle Voltage	220	220	220/380	380	380	380	380
出力(Kw) Power S1	2.2	3	6.4/10	15	20	21	25
出力(Kw) Power S6	2.5	3.6	7.2/ 12	18	22.5	23.5	29
扭力(Nm) Torque S1	0.72	1.5	3.4/5.5	14.8	32.9	101	83.2
扭力(Nm) Torque S6	0.82	1.8	4.1/6.6	17.6	38.5	114	99.3
主軸冷卻方式 Spindle cooling method	油冷 Oil	水冷 Water	水冷 Water	水冷 Water	水冷 Water	水冷 Water	水冷 Water
刀把型式 Clamping type	ER16	ISO25/HSK E40	BT30/HSK E40	BT40/HSK A63	HSK A63	HSK A63	HSK A63
軸承溫度感測器 Bearing temperature sensor	Yes	Yes	Yes	Yes	Yes	Yes	Yes
編碼器 Encoder	-	-	選配 Optional	Yes	Yes	Yes	Yes
旋轉接頭 Rotary joint	-	-	選配 Optional	選配 Optional	選配 Optional	選配 Optional	選配 Optional
主軸長度MM Spindle length	220	385	451	541	592	718	654
主軸重量KG Spindle weight	6	14	23	45	60	120	138



SMG 58



SMG 120



SMG 215



產品型號 Product Model	SMG58	SMG120	SMG150	SMG215	SMG230
主軸外徑 Spindle outer diameter	Ø 58	Ø 120	Ø 150	Ø 215	Ø 230
最高轉速 rpm Max Speed	20000	30000	10000	10000	-
	油脂潤滑 Grease lubrication	-	-	-	油氣潤滑 Oil-air lubrication
主軸電壓 Spindle Voltage	220	220	380	380	380
出力(Kw) Power S1	0.48	10	5.5	24	26
出力(Kw) Power S6	0.52	12	6.3	28	30
扭力(Nm) Torque S1	0.229	5.5	19.5	38.2	124
扭力(Nm) Torque S6	0.251	6.5	22.6	44.8	148
主軸冷卻方式 Spindle cooling method	氣冷 Air	水冷 Water	油冷 Oil	油冷 Oil	水冷 Water
刀把型式 Clamping type	Ø20	M22*P1.5	HSK E50	HSK E50	HSKA100
軸承溫度感測器 Bearing temperature sensor	-	Yes	Yes	Yes	Yes
主軸長度MM Spindle length	208	340	498	687	793
主軸重量KG Spindle weight	3	20	41	105	177



特色：

RTS 規格是自動化系統的延伸交換，可以透過自動連接系統裝配非常廣泛的配件 (如銑頭、研磨頭、迴轉頭等等)，同時保持 RAM 極其緊湊的尺寸。RTS 可用於不同的機器配置 (包含立式車床、臥式銑床和龍門機床) 以及多工操作 (包含車削、銑削、鑽孔和磨削)，從而實現非常高的靈活性。最後，機器易於組裝和維護：

- 位於滑枕頂部的快速連接裝置。
- 可以輕鬆快速地從滑枕前部取出主軸。

Features:

RTS models are an extension of the motorizations that can be equipped with a very wide range of accessories (heads, grinding extensions, turning turrets, etc...), by an automatic attachment system, while maintaining extremely compact dimensions of the RAM. RTS can be used in different machine configurations (vertical lathes, horizontal milling and gantry) and for multitasking operations (turning, milling, drilling and grinding), allowing a very high flexibility level. Last but not least, the ease of assembly and maintenance on the machine with:

- Quick connections and couplings positioned at the top of the RAM.
- Possibility of easy and quick extraction of the spindle from the front of the RAM.



特色：

RGB系統 (Ram Gear Box) 是這個系列中最完整的方案。他具有重要的技術內容，結合了小尺寸中的高扭矩性能，特別適用於立式 (龍門或雙柱) 和臥式機床。總體特點類似於RTS產品：

- 配件 (如頭部或延長件) 的自動連接系統。
- 多工加工操作
- 機器易於組裝和維護：
 - 位於滑枕頂部的快速連接裝置。
 - 可以輕鬆快速地從滑枕前部取出主軸。

Features:

The RGB system (Ram Gear Box) is the most complete solution within this family, with important technological contents, that combines high torque performance in small dimensions particularly appreciated for vertical (gantry or double column) and horizontal axis machine tools. The general characteristics are similar to the RTS products:

- Automatic attachment system for the accessories (like heads or extensions).
- Multitasking machining operations
- Easiness of assembly and maintenance on the machine with:
 - Quick connections and couplings positioned at the top of the RAM.
 - Possibility of easy and quick extraction of the spindle from the front of the RAM.

叉式二軸頭
Fork Head

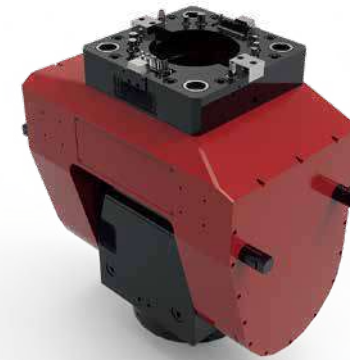

90°延長頭
90° Extension Head



Y軸
Y Axis



連接蓋板
Milling Cover



Grinding Extension Head
磨削延伸頭



Grinding Extension Head
磨削延伸頭



Automatic Turning Block
自動轉向塊



Fixed Turning Block
固定轉向塊

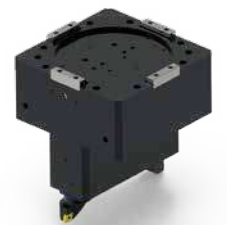

AC 16



AC 8M





AC 7







AC 7M



AC 16		
C軸最大旋轉角度 =視連接結構而定 C-axis swivel range (max.) =Dependent on connection construction		+/-360°
C軸最大速度 C-AXIS SPEED (max.)	+/s	360
C軸最大加速度 C-AXIS ACCELERATION (max.)	+/s ²	600
C軸夾緊扭矩(無壓/增壓) C-AXIS CLAMPING TORQUE (Pressureless / With boost)	Nm	456/820
C軸扭矩 C-AXIS TORQUE	Nm	350
C軸測量系統精度 C-AXIS MEASURING SYSTEM ACCURACY	-	+/-3.3
A軸最大旋轉角度 A-AXIS SWIVEL RANGE (max.)	-	+/-110°
A軸最大速度 A-AXIS SPEED (max.)	+/s	360
A軸最大加速度 A-AXIS ACCELERATION (max.)	+/s ²	600
A軸夾緊扭矩 (無壓 / 增壓) A-AXIS CLAMPING TORQUE (Pressureless / With boost)	Nm	456 / 820
A軸扭矩 A-AXIS TORQUE	Nm	350
A軸測量系統精度 A-AXIS MEASURING SYSTEM ACCURACY	-	+/-3.3
不含主軸的重量 WEIGHT WITHOUT SPINDLE (APPROX...)	Kg	220
主軸最大直徑 : Ø 170 MAX. SPINDLE : Ø 170		

AC 8M					
C軸 C-AXIS			A軸 A-AXIS		
採用 GGG50 鑄鐵安裝法蘭的外殼。 Housing with mounting flange in GGG50 cast iron. 軸承, 油脂潤滑 (軸向/徑向) 圓柱滾子軸承。 Axis bearing, grease lubricated (axial/radial) cylindrical roller bearing.					
C軸旋轉角度 C-AXIS ROTATION ANGLE (max.)		+/-360°	A軸旋轉角度 A-AXIS ROTATION ANGLE (max.)		+/-110°
C軸轉速 C-AXIS ROTATION SPEED (max. S1)	°/s	300	A軸轉速 A-AXIS ROTATION SPEED (max. S1)	°/s	300
C軸加速度 C-AXIS ACCELERATION (max.)	°/s ²	800	A軸加速度 A-AXIS ACCELERATION(max.)	°/s ²	800
C軸額定扭矩 C-AXIS NOMINAL TORQUE	Nm	1500	A軸額定扭矩 A-AXIS NOMINAL TORQUE	Nm	1500
C軸最大扭矩 C-AXIS PEAK TORQUE	Nm	2000	A軸最大扭矩 A-AXIS PEAK TORQUE	Nm	2000
C軸保持扭矩 C-AXIS HOLD UP TORQUE	Nm	1000	A軸保持扭矩 A-AXIS HOLD UP TORQUE	Nm	1000
C軸夾緊扭矩 C-AXIS CLAMPING TORQUE		6000	A軸夾緊扭矩 A-AXIS CLAMPING TORQUE		6000
C軸精度 C-AXIS MEASURING SYSTEM ACCURACY		+/-3.2"	A軸精度 A-AXIS MEASURING SYSTEM ACCURACY		+/-3.2"
C軸夾緊類型 C-AXIS CLAMPING TYPE		液壓夾緊, 彈簧鬆開 clamped by hydraulic, unclamping by spring	A軸夾緊類型 A-AXIS CLAMPING TYPE		液壓夾緊, 彈簧鬆開 clamped by hydraulic, unclamping by spring

AC 7					
C軸 C-AXIS			A軸 A-AXIS		
採用 GGG50 鑄鐵安裝法蘭的外殼。 Housing with mounting flange in GGG50 cast iron. 軸承, 油脂潤滑 (軸向/徑向) 圓柱滾子軸承。 Axis bearing, grease lubricated (axial/radial) cylindrical roller bearing.					
C軸旋轉角度 C-AXIS ROTATION ANGLE (max.)		+/-360°	A軸旋轉角度 A-AXIS ROTATION ANGLE (max.)		+/-110°
C軸轉速 C-AXIS ROTATION SPEED (max. S1)	°/s	300	A軸轉速 A-AXIS ROTATION SPEED (max. S1)	°/s	300
C軸加速度 C-AXIS ACCELERATION (max.)	°/s ²	1200	A軸加速度 A-AXIS ACCELERATION(max.)	°/s ²	1200
C軸額定扭矩 C-AXIS NOMINAL TORQUE	Nm	610	A軸額定扭矩 A-AXIS NOMINAL TORQUE	Nm	610
C軸最大扭矩 C-AXIS PEAK TORQUE	Nm	960	A軸最大扭矩 A-AXIS PEAK TORQUE	Nm	960
C軸保持扭矩 C-AXIS HOLD UP TORQUE	Nm	404	A軸保持扭矩 A-AXIS HOLD UP TORQUE	Nm	404
C軸夾緊扭矩 C-AXIS CLAMPING TORQUE	Nm	3000	A軸夾緊扭矩 A-AXIS CLAMPING TORQUE		3000
C軸精度 C-AXIS MEASURING SYSTEM ACCURACY		+/-3.3"	A軸精度 A-AXIS MEASURING SYSTEM ACCURACY		+/-3.3"
C軸夾緊類型 C-AXIS CLAMPING TYPE		液壓夾緊, 彈簧鬆開 clamped by hydraulic, unclamping by spring	A軸夾緊類型 A-AXIS CLAMPING TYPE		液壓夾緊, 彈簧鬆開 clamped by hydraulic, unclamping by spring

AC 7M					
C軸 C-AXIS			A軸 A-AXIS		
採用 GGG50 鑄鐵安裝法蘭的外殼。 Housing with mounting flange in GGG50 cast iron. 軸承, 油脂潤滑 (軸向/徑向) 圓柱滾子軸承。 Axis bearing, grease lubricated (axial/radial) cylindrical roller bearing.					
C軸旋轉角度 C-AXIS ROTATION ANGLE (max.)		+/-360°	A軸旋轉角度 A-AXIS ROTATION ANGLE (max.)		+/-110°
C軸轉速 C-AXIS ROTATION SPEED (max. S1)	°/s	360	A軸轉速 A-AXIS ROTATION SPEED (max. S1)	°/s	360
C軸加速度 C-AXIS ACCELERATION (max.)	°/s ²	800	A軸加速度 A-AXIS ACCELERATION(max.)	°/s ²	800
C軸額定扭矩 C-AXIS NOMINAL TORQUE	Nm	1020	A軸額定扭矩 A-AXIS NOMINAL TORQUE	Nm	1058
C軸保持扭矩 C-AXIS HOLD UP TORQUE	Nm	792	A軸保持扭矩 A-AXIS HOLD UP TORQUE	Nm	818
C軸夾緊扭矩 C-AXIS CLAMPING TORQUE	Nm	2000/4000	A軸夾緊扭矩 A-AXIS CLAMPING TORQUE		2000/4000
C軸精度 C-AXIS MEASURING SYSTEM ACCURACY		+/-2.5"	A軸精度 A-AXIS MEASURING SYSTEM ACCURACY		+/-2.5"
C軸夾緊類型 C-AXIS CLAMPING TYPE		液壓夾緊, 彈簧鬆開 clamped by hydraulic, unclamping by spring	A軸夾緊類型 A-AXIS CLAMPING TYPE		液壓夾緊, 彈簧鬆開 clamped by hydraulic, unclamping by spring





TILT 系列



ORBITAL 系列

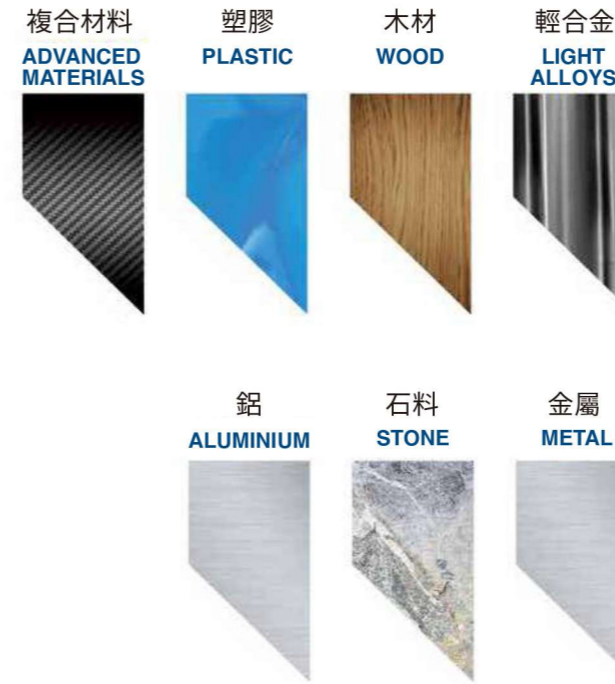

技術規格 TECHNICAL SPECIFICATIONS	TILT G		TILT G PLUS		TILT M		ORBITAL M	
	A軸 A AXIS	C軸 C AXIS	A軸 A AXIS	C軸 C AXIS	A軸 A AXIS	C軸 C AXIS	A軸 A AXIS	C軸 C AXIS
軸電機 Axis motor	Direct drive	Direct drive	Direct drive	Direct drive	Direct drive	Direct drive	Direct drive	Direct drive
額定扭矩 Rated torque	504 Nm	533 Nm	504 Nm	787 Nm	830 Nm	787 Nm	560 Nm	787 Nm
最大扭矩 Peak torque	1000 Nm	935 Nm	1000 Nm	1560 Nm	1472 Nm	1560 Nm	1030 Nm	1560 Nm
最大轉速 Max axes speed	30000°/'		30000°/'		30000°/'		30000°/'	
軸編碼器 Measuring system	增量式編碼器 Incremental encoder		增量式編碼器 Incremental encoder		增量式編碼器 Incremental encoder		增量式編碼器 Incremental encoder	
定位精度 Accuracy of graduation	±2,5 arcsec	±3,0 arcsec	±2,5 arcsec	±2 arcsec	±2 arcsec	±2 arcsec	±3,8 arcsec	±2 arcsec
煞車類型 Type of clamping	液壓 Hydraulic		液壓 Hydraulic		液壓 Hydraulic		氣壓 Pneumatic	液壓 Hydraulic
煞車扭矩 Clamping torque	3000 Nm	3000 Nm	3000 Nm	4000 Nm	4000 Nm	4000 Nm	3720 Nm	4000 Nm
最大軸旋轉 Max axis rotation	±120°	±360°	±120°	±360°	±110°	±360°	±185°	±360°
C軸安裝配合直徑 Head fitting diameter	Ø 310		Ø 335		Ø 335		Ø 335	
主軸直徑 Spindle fitting diameter	Ø 180		Ø 180		Ø 210 (Ø 180)		Ø 210 (Ø 180)	
重量 Weight	500 kg		650 kg		800 kg		650 kg	

主軸型號 Product	主軸 Spindle					
	MX-2 42/12 24	MX-2 42/6 24	MX-2 41/4.5 24	MX-2 38/3 12	MX-2 47/3 12	MX-2 60/3 12
主軸外徑 Ø Spindle outer diameter	180	180	180	210	210	210
油氣潤滑 Oil-air lubrication	28000	24000	24000	15000	15000	15000
出力(Kw) Power S1	42	42	41	38	47	60
出力(Kw) Power S6	48	48	47	43	54	69
扭力(Nm) Torque S1	34	67	87	120	150	191
扭力(Nm) Torque S6	39	76	100	137	172	220
主軸冷卻方式 Spindle cooling method	水冷 Water	水冷 Water	水冷 Water	水冷 Water	水冷 Water	水冷 Water
刀把型式 Clamping type	HSK 63A	HSK 63A	HSK 63A	HSK 100A	HSK 100A	HSK 100A
軸承溫度感測器 Bearing temperature sensor	標配	標配	標配	標配	標配	標配
主軸重量KG Spindle weight	70	70	70	110	110	110



特品國際成立於1988年，以代理歐洲知名品牌起家，於2008年開始在台灣生產刀塔。

我們致力於機床關鍵零組件 – 刀塔、主軸、刀座等的鑽研。以智能設計、專業技術、創新服務為基礎，以客戶需求為導向，客製化ODM、OEM服務，提升機床產業的全球競爭力與機台特殊性，成為全球機床業之關鍵零組件技術領導者及首選之合作夥伴。

為落實ESG (環境保護、社會責任、公司治理) 理念，廠區安裝節電設備，同時與協力廠商一同尋找並開發新原料。透過製程優化以降低或避免因製造過程對環境造成之任何負面影響。

GP Machinery was founded in 1988, started as an agent for well-known European brands.

We started to manufacture turrets in Taiwan since 2008. Satisfying customer demands is our guideline.

Intelligent design, professional technology and innovative services are our fundamentals. We are dedicated to provide world-class products and customized ODM, OEM solutions, to become the global leader in key components of machine tool industry, and to be the No. 1 preferred partner of machine tool builders around the world.

In order to implement the concept of ESG (environmental protection, social responsibility, corporate governance). The factory installs energy-saving equipment and works with third parties to find and develop new raw materials. Reduce or avoid any negative impact on the environment caused by the manufacturing process through process optimization.

Linktree /    



特品 GP



霄特 GPM



德霄 GP Int'l



Sauter

1946

1946年德國SAUTER創立 德國第一刀塔品牌 SAUTER Feinmechanik GmbH. established in 1946.



1988

1988年成立特品國際 德國SAUTER台灣總代理 GP Machinery Co., Ltd. established in 1988. As agent of Sauter in Taiwan. Location : Taiwan / Business : Spindle, Processing



2002

2002年創立並在台灣生產自有主軸品牌SPINMARS Owned Spindle brand "SPINMARS" since 2002. Made in Taiwan.

2007

2007年成立上海德霄 GP International Co., Ltd.(Shanghai) established in 2007. Business : Sales & After-sales service for Turret & Spindle in China.

Sauter

2008

2008年德國SAUTER與台灣特品(GP)合資成立 霄特國際股份有限公司(SAUTER ASIA) 同年在台開始生產刀塔 SAUTER ASIA established in 2008. (Joint venture company of Sauter Germany and GP) Turret made in Taiwan since 2008. Business : Turret, Tool Holders.



2018

2018年代理義大利 SCM Group-HITECO 品牌 As agent for "SCM Group-HITECO" since 2018.



2019

2019年代理義大利 IMA TECNO 品牌 As agent for "IMA TECNO" since 2019.



2022

2022年代理德國五軸頭 TRAMEC 品牌 As agent for "TRAMEC" since 2022.



2022

2022年04月購入德國 SAUTER 65%持股。霄特成為100%台灣獨資。 Apr.2022 – Purchased 65% share from Sauter Germany; Became 100% owned by Taiwanese shareholders.

2022年06月更名為 GPM Co., Ltd. 霄特國際股份有限公司 (中文名不變) Jun.2022 – Changed company name to GPM CO., LTD. (formerly known as Sauter Asia Co.,LTD.)



Other Special Tool Holder

其他特殊刀座

軸向偏心動力刀座
Axial drilling and
milling head offset



萬向動力刀座
Universal live
tool holder



滾齒動力刀座
Gear hobbing unit



插槽動力刀座
Broaching unit



側銑動力刀座
Side milling cutter

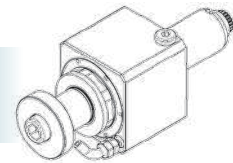

VDI測試棒
Testing mandrel

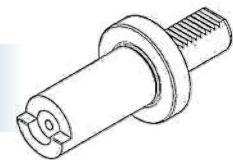

BMT測試棒
Testing mandrel

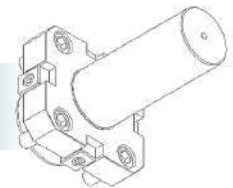

單點車銑座
Milling head

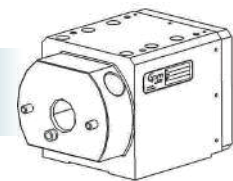

Various Tool Holder Interfaces Available

提供各型式歐美及日系介面刀座

DIN5480



DIN5482



DIN1809



SPUR MT TOEM
(Baruffaldi)



Okuma



HASS



DOOSAN



MAZAK



MoriSeiki



Nakamura



刀座型錄
Tool Holder



As Agent for SAUTER

GPM 代理

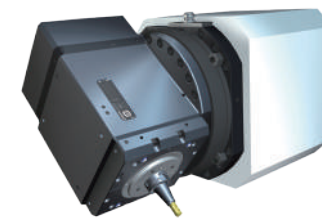

搖擺頭車銑主軸
Motor spindle with DD table



車銑主軸+旋轉機構
Motor spindle with B-Axis

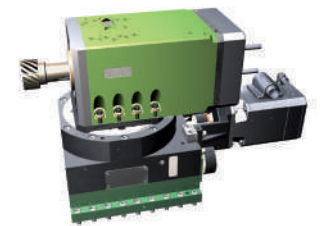

437 Series
內藏式馬達刀塔
Direct Drive Turret



170 Series
專用機用刀塔
Crown-Type Turret

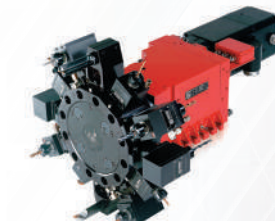

450 Series
單馬達刀塔
Single Motor Turret

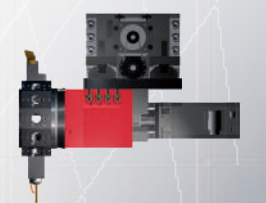

453 Series
Y軸刀塔
Y-Axis Turret

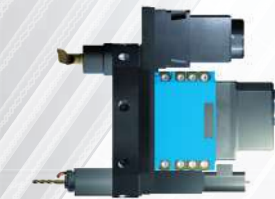

473 Series
電動動力刀塔
Electromechanical
drive live turret



480 Series
電動非動力刀塔
Electromechanical
drive static turret



320 Series
四方刀塔
Head Type Turret

ATC Turret
自動換刀刀塔

刀座搭配Capto自動換刀系統

Tool holder equipped with Capto automatic clamping unit - Achieving auto tool change by hydraulic clamp & unclamp

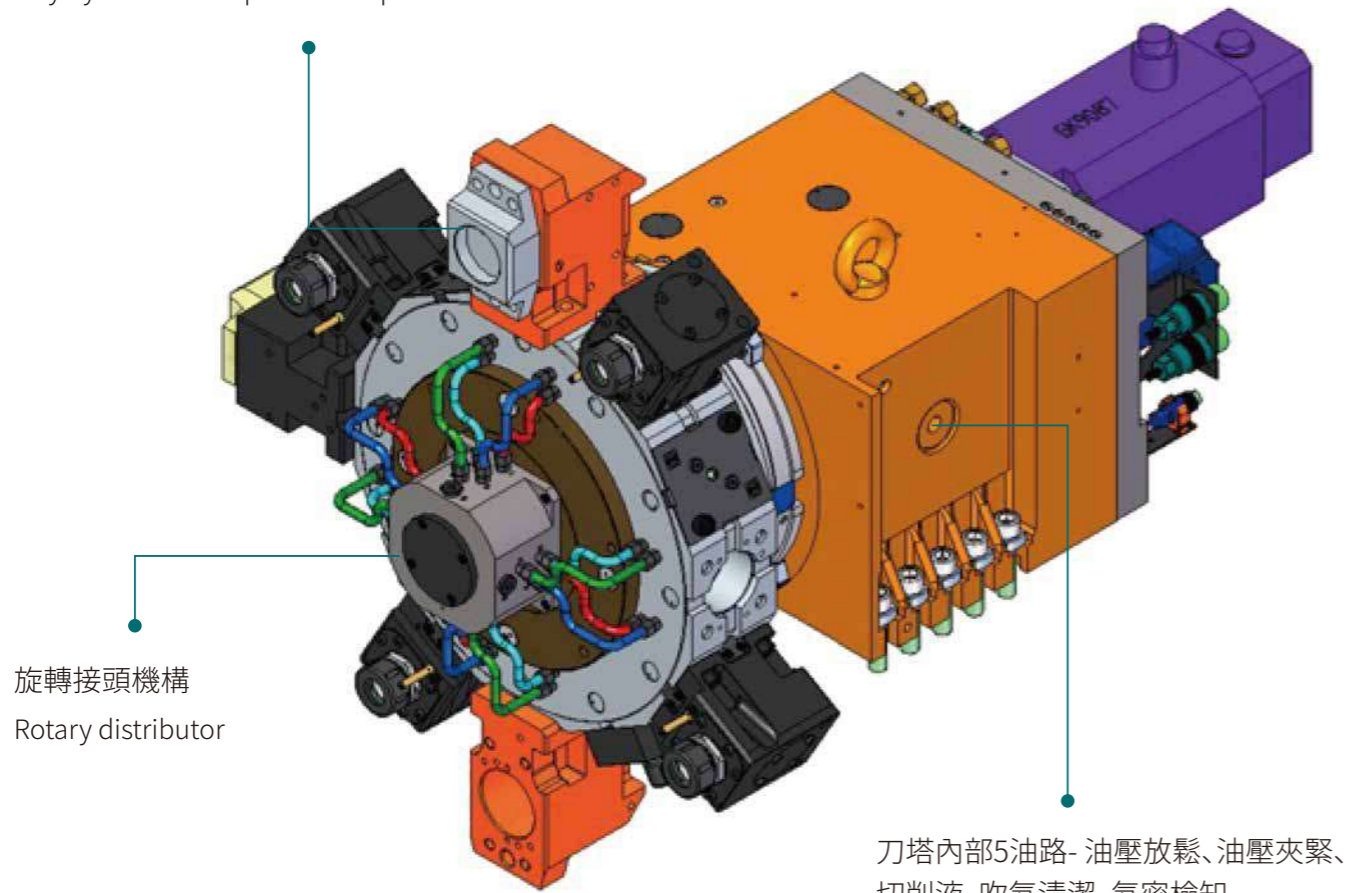

旋轉接頭機構
Rotary distributor

刀塔內部5油路- 油壓放鬆、油壓夾緊、切削液、吹氣清潔、氣密檢知

5 channels for hydraulic clamp, unclamp, coolant, air blast and probe contact

Double Upgrade- Performance & Intelligence
434 BMT動力刀塔 - 性能 智能 雙重升級

產品優勢:

- 高速長時運轉
- 降低熱變形
- 提高刀座負載量
- 超高壓出水

Advantages:

- High speed and long time operation
- Reducing thermal deformation
- Increasing tool holder loading capacity
- High pressure coolant

產品特色:

- 動力刀轉速6000rpm 以內, 可連續加工運轉
- 動力刀轉速8000rpm, 連續運轉30mins, 刀盤熱位移量<10µm, 溫度<65°C
- 免電池絕對式轉位馬達, 永久不用更換電池
刀座負載量提高100%
- 高壓出水: 25~150bar
- PT-1000 高精度溫度感測器

Features:

- Tool drive speed < 6000rpm : continuously operation allowed
- Tool drive speed at 8000rpm : continuous operation for 30mins : thermal displacement of tool disc <10µm, temperature < 65°C
- Battery free indexing motor (absolute) ; no need to replace battery.
Tool holder loading capacity : increase 100%
- High pressure coolant : 25~150bar
- PT-1000 high precision temperature sensor

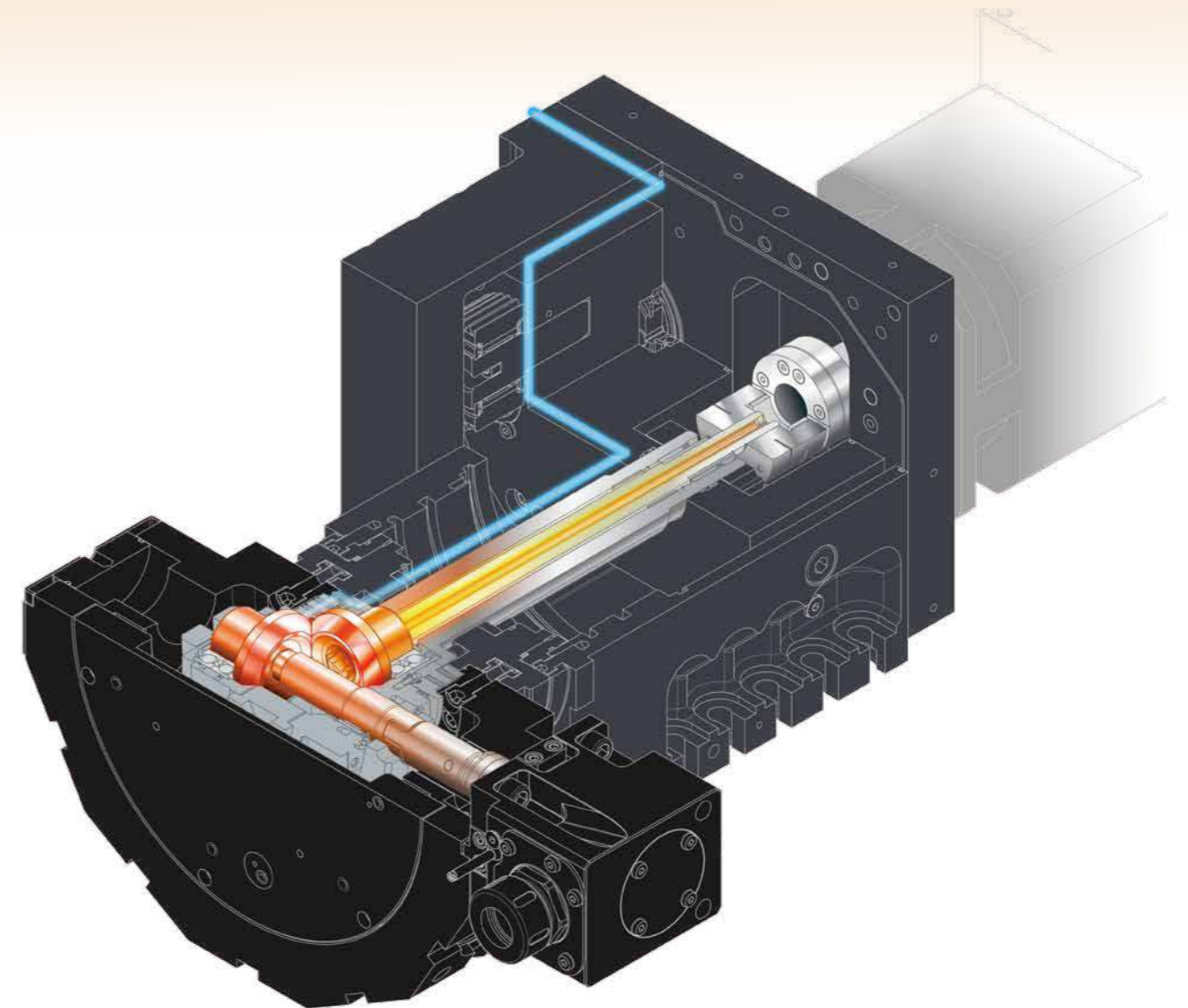

2D 動畫



Driven turret with Y-axis Y 軸動力刀塔

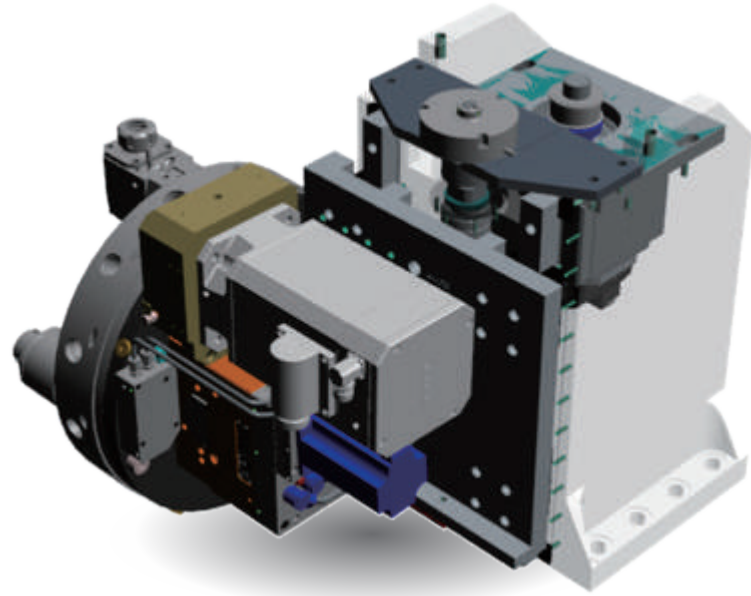

外掛式：

- 適用於單主軸／雙主軸車床
- 2線軌及一螺桿
- Y軸行程±50~60mm
- Y軸電磁剎車另可外加馬達剎車, 雙重保障

External mount type :

- Suitable for single/two spindles machines.
- 2 linear guide/1 ball screw design.
- Y axis travel: ±50~60mm.
- Y axis equipped with electromagnetic brake.
- Add additional motor brake is possible.

中置式：

- 四線軌及一螺桿
- 干涉小, 節省30%配置空間
- 應用面: 可配置斜床身, 擺脫傳統外掛式Y軸重量限制
- 適合中/輕切削

Central mount type:

- 4 linear guide center-mounted screw design.
- Interference is reduced by about 30%.
- Suitable for high-complex processing.
- Suitable for medium~light cutting.

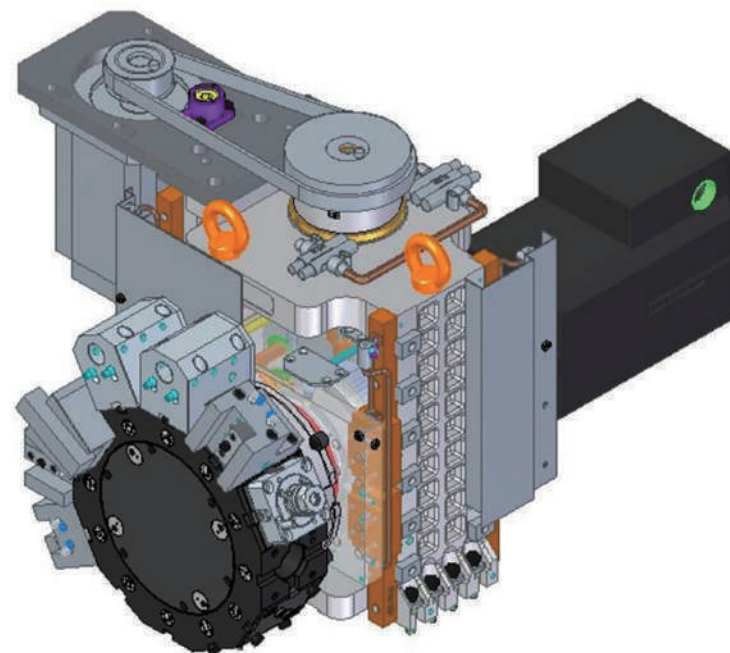

ODM / OEM 客製化設計能力

- 可配合機床設計, 提供客製化解決方案, 如 特殊刀塔本體、刀盤、刀座等。
- 因應自動化生產需求, 刀塔可另外搭載如夾爪、中心架及其他特殊需求等。

Customized ability

- Customized designs to suit different demands of machines, such as special turret housing, tool disc and tool holder..etc.
- Turret may be redesigned to integrate gripper, steady rest, ..etc for automated manufacturing.

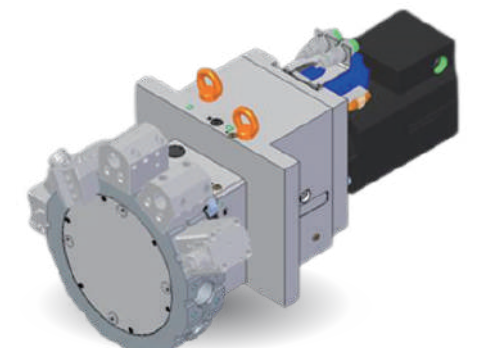
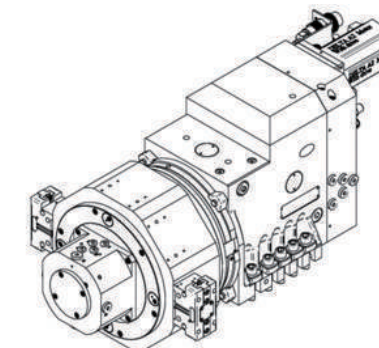
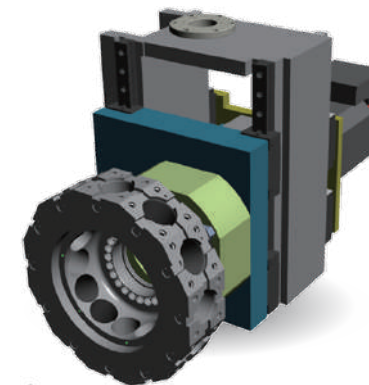
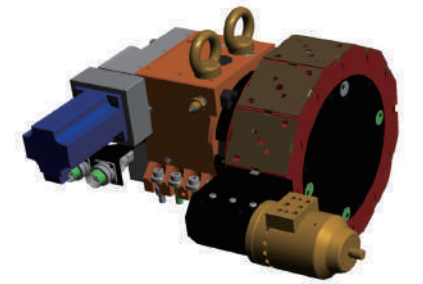
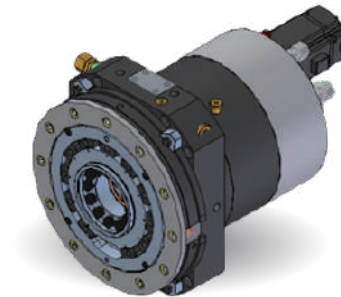
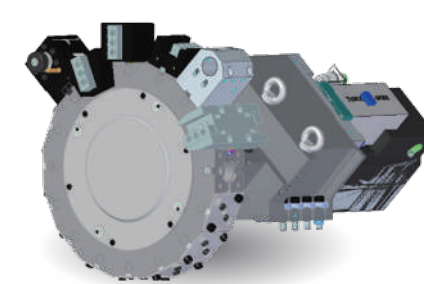
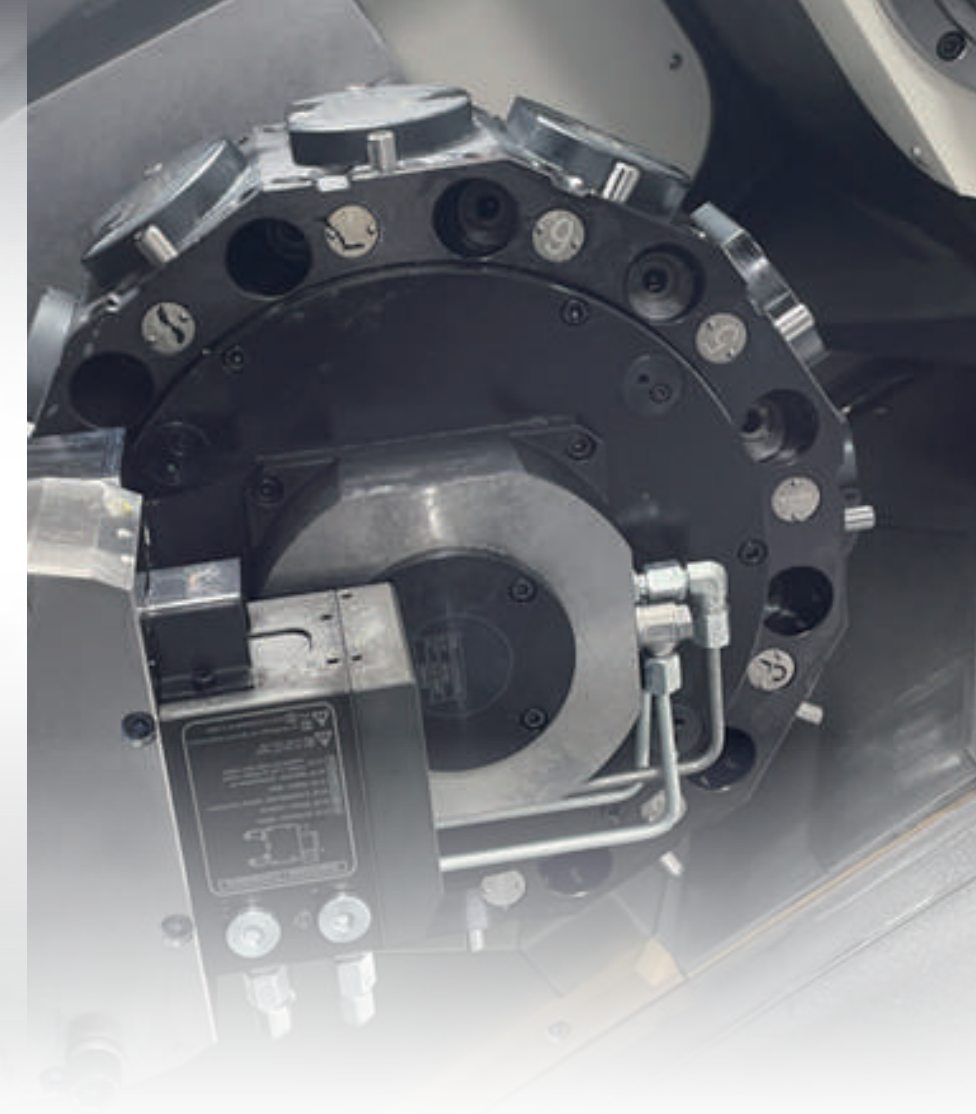

刀塔選型
Turret Product info

434/BMT Radial Mount Driven Turret 434 BMT徑向動力刀塔

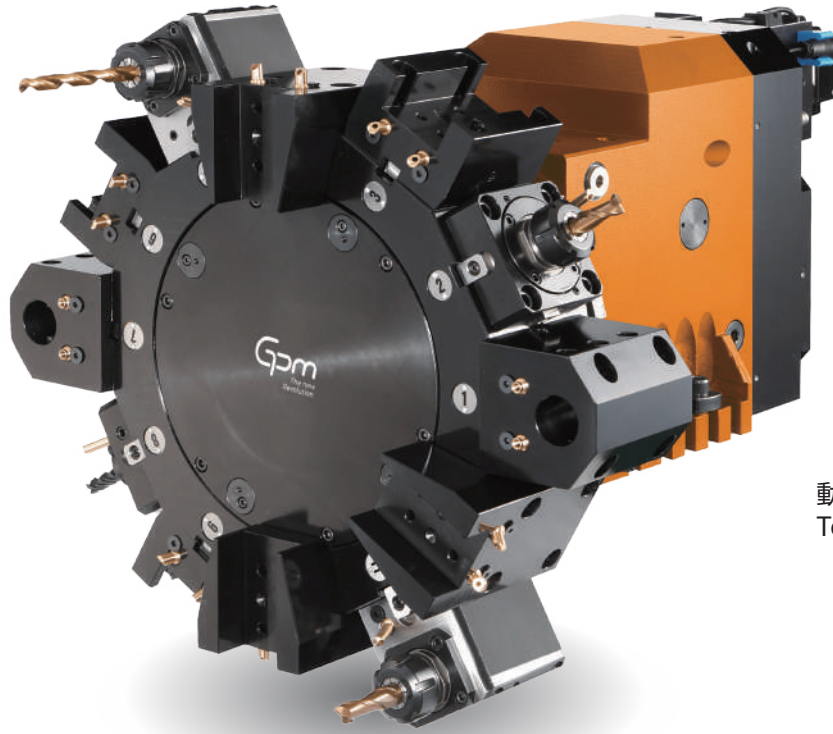

動力刀馬達 - U型連結
Tool drive motor - U-shape connection

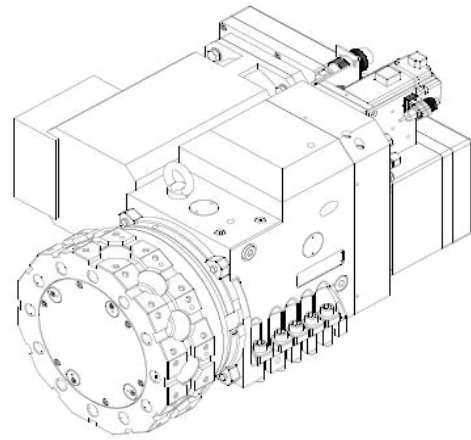

特色：

- 刀塔本體形狀多樣化 (如 LF, BF, HL, HB, MF 等), 滿足不同機床內部設計結構與空間。
- BMT :採用Doosan 介面, 適合重切削
- 動力刀馬達可U型安裝, 節省安裝空間

Features:

- Multiple housing shapes available, such as LF, BF HL, HB, MF ..etc to suit different machine design.
- BMT (Doosan) interface, suitable for heavy cutting.
- Tool drive motor may be mounted in U-shape, installation space is saved.

外徑刀座 Turning Holder

外徑刀座 C
Turning tool holder

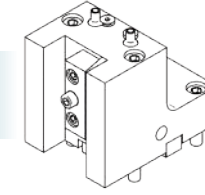

外徑刀座 C
Turning tool holder

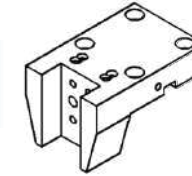

搪孔刀座 B
Boring tool holder

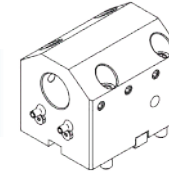

端面刀座F
Facing tool holder

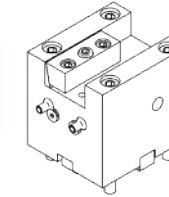

切斷刀座
Cutting holder

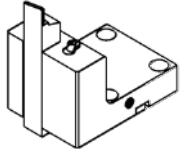

0度動力刀座
Driven tool holder-0
Degree

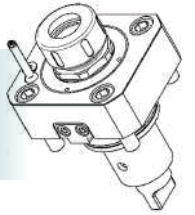

90度動力刀座
Driven tool holder-90
Degree

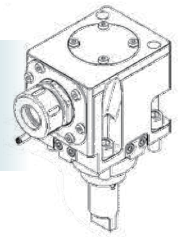

標準配置 Standard Configuration

機種 Type	規格 Specifications
434.016	434.016/NH80/BMT45/SW290/W3
	434.016/NH100/BMT55/SW330/W3
434.020	434.020/NH100/BMT45/SW290/W3
	434.020/NH125/BMT45/SW340/W3
	434.020/NH140/BMT45/SW340/W3
	434.020/NH125/BMT45/SW390/16T/W3
	434.020/NH100/BMT55/SW330/W3
	434.020/NH125/BMT55/SW330/W3
	434.020/NH140/BMT55/SW330/W3
434.025	434.020/NH100/BMT65/SW380/W3
	434.020/NH100/BMT65/SW380/W3
	434.020/NH125/BMT65/SW380/W3
434.032	434.025/NH150/BMT75/SW430/W3
	434.025/NH180/BMT75/SW430/W3
434.032	434.032/NH200/BMT85/SW530/W3

434動力刀塔齒輪頭性能參數 Technical data of gear head

項目 Item	尺寸與規格 Size & Specifications			
機型規格 Type	16	20	25	32
刀具介面 Interface (BMT)	45/55	45/55/65	75	85
齒輪頭特性 Gear head performance data				
容許驅動功率 Admissible drive rating P _{adm} (Kw)	8	10	12.5	16
容許驅動扭矩 Admissible torque M _{adm} (Nm)	32	63	100	180
容許轉速 Admissible rpm n _{adm} (rpm)	6000	6000	4000	4000
傳動比 Gear ratio	1.0	1.0	1.0	1.0
建議配置的動力馬達 (IP67) Recommended tool drive motor (IP67)				
Siemens 伺服馬達 servo motor Type 1FK7..	..084	..086	..105	..108
Fanuc 伺服馬達 α servo motor	12/6000 is	22/4000 is	40/4000 is	50/3000
Fanuc 主軸馬達 α Spindle motor	2	3	6/8	15 HVi



刀塔選型
Turret Product info



刀座型錄
Tool Holder

435/VDI Radial Mount Driven Turret
435 VDI徑向動力刀塔

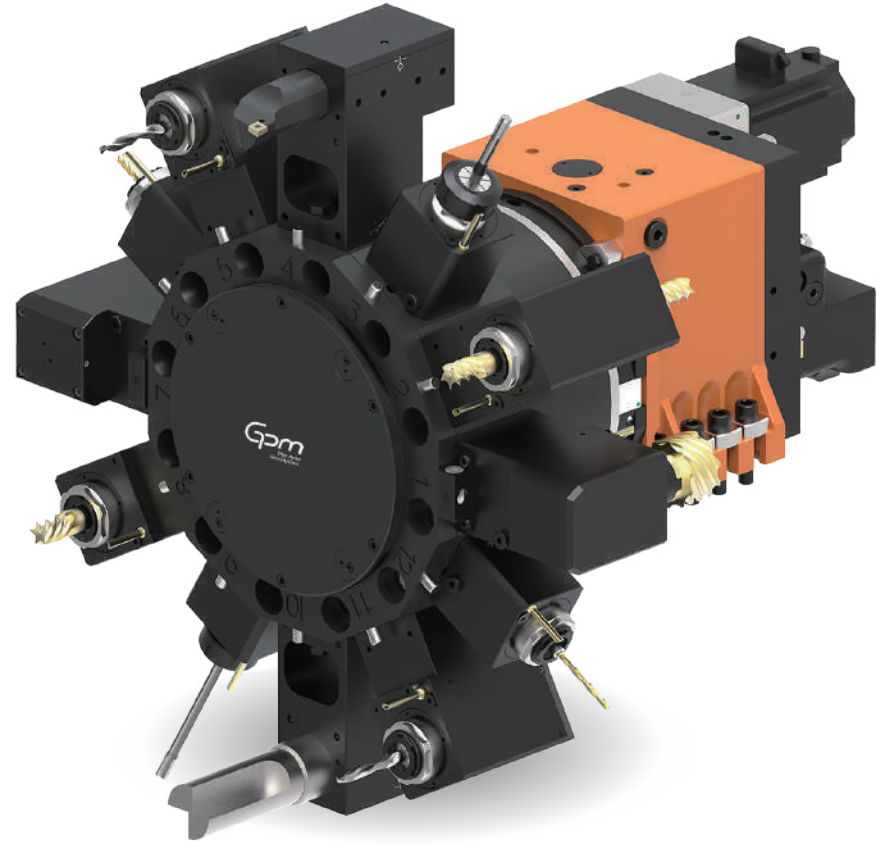

特色:

- 435/VDI 徑向動力刀塔與動力刀座採DIN5480系統; 通過動力刀系統的耦合齒與動力刀座的定位環以達到雙重定位。
- DIN5480傳動: 可減少花鍵齒的磨耗、降低噪音、增加速度與延長零件壽命。

Features:

- 435/VDI radial mount driven turret and driven tool holder adopt DIN5480 system; dual positioning is achieved through coupling of tool drive system and the indexing ring of driven tool holder.
- DIN5480 transmission: may reduce teeth damage, reduce noise, increase speed and extend parts life.

標準配置
Standard Configuration

機種 Type	規格 Specifications
435.216	435.216/12T/SW270/VDI30/W3
	435.216/12T/SW340/VDI30/W3
435.220	435.220/12T/SW320/VDI40/W3
435.220	435.220/12T/SW380/VDI40/W3

徑向VDI刀盤-加工方式
Tooling for radial mount

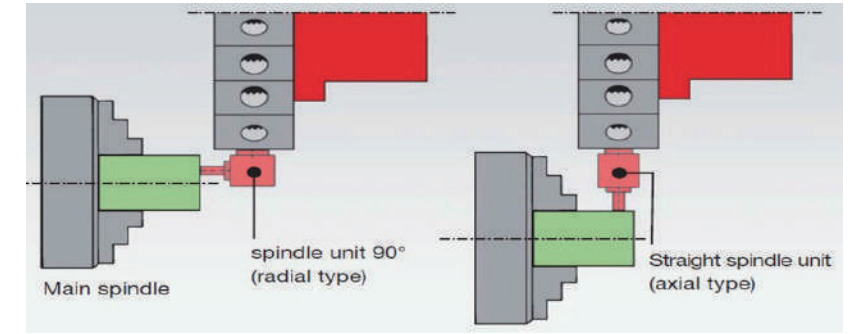

435動力刀塔齒輪箱性能參數
Technical data of gear box

項目 Item	尺寸與規格 Size & Specifications	
機型規格 Type	16	20
刀具介面 Interface	VDI30	VDI40
齒輪箱特性 Gearbox performance data		
容許驅動功率 Admissible drive ratio P _{adm} (Kw)	8	20
容許驅動扭矩 Admissible torque M _{adm} (Nm)	32	63
容許轉速 Admissible rpm n _{adm} (rpm)	5000	4000
傳動比 Gear ratio (i=n1/n2)	1.0	1.0
建議配置的動力馬達(IP67) Recommended tool drive motor (IP67)		
Siemens伺服馬達 servo motor Type 1FK7..	..084	..086
Fanuc伺服馬達 α servo motor	12/4000 is	22/4000 is
Fanuc主軸馬達 α Spindle motor	2	3

刀座
Tool Holder

B2系列 Type		0度動力刀座 Driven tool holder- 0 Degree	
B3系列 Type		90度動力刀座 Driven tool holder- 90 Degree	
C2系列 Type		90度後縮動力刀座 Offset driven tool holder-90 Degree	
C3系列 Type		ER筒夾 Collet chuck	
搪孔刀座 Boring tool holder E2系列 type		套筒 Sleeve	



刀塔選型
Turret Product info



刀座型錄
Tool Holder

VDI Axial Mount Driven Turret 436 VDI軸向動力刀塔

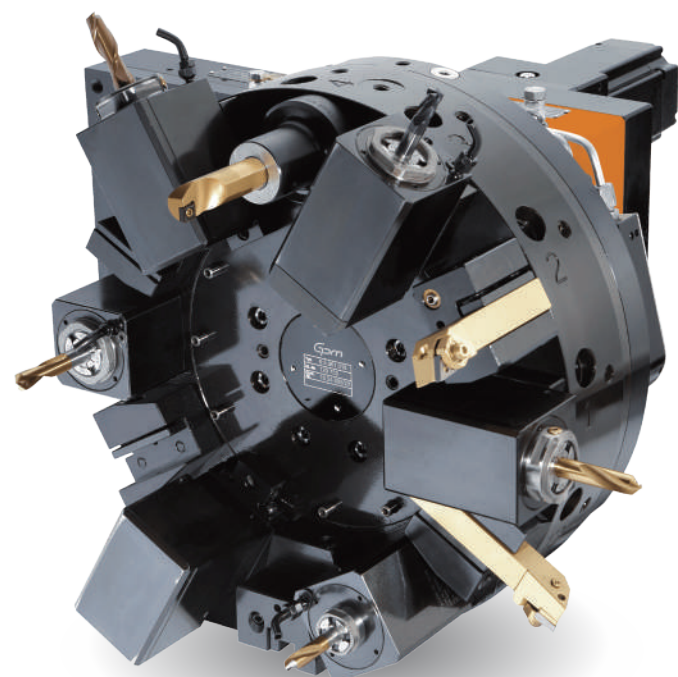

多邊形刀盤
Polygon type tool disc

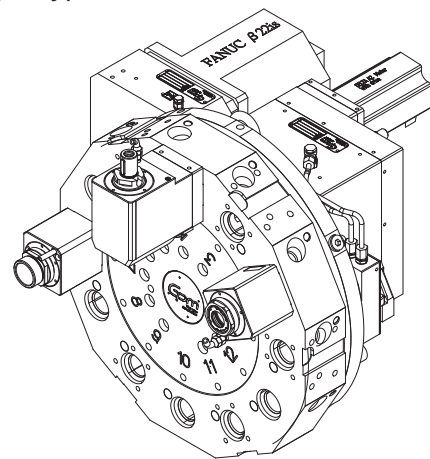

- 內圈安裝動力刀座
- 外圈安裝固定刀座
- Position with tool drive
- Position w/o tool drive

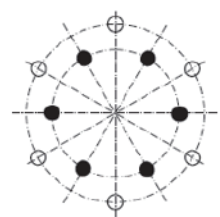

12刀 - 雙PCD
12Pos. - 2 graduated circles

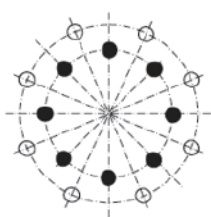

16刀 - 雙PCD
16Pos. - 2 graduated circles

特色:

- 436/VDI軸向動力刀塔與動力刀座採DIN5480系統；通過動力刀系統的耦合齒與動力刀座的定位環以達到雙重定位。
- DIN5480傳動：可減少花鍵齒的磨耗、降低噪音、增加速度與延長零件壽命。
- 亦可視加工需求搭載多邊形刀盤（軸、徑向皆可安裝刀座）或雙PCD刀盤。

Features:

- 436/VDI axial mount driven turret and driven tool holder adopt DIN5480 system; dual positioning is achieved through coupling of tool drive system and the indexing ring of driven tool holder.
- DIN5480 transmission: may reduce teeth damage, reduce noise, increase speed and extend parts life.
- Depending on processing demands, polygonal tool disc or dual PCD tool disc may be used on 436/VDI turret.

436動力刀塔齒輪箱性能參數 Technical data of gear box

項目 Item	尺寸與規格 Size & Specifications				
機型規格 Type	12	16	20	25	32
刀具介面 Interface (VDI)	25/30	30/40	30/40	50	60
齒輪箱特性 Gearbox performance data					
容許驅動功率 Admissible drive ratio Padm (Kw)	6	8	10	12.5	16
容許驅動扭矩 Admissible torque Madm (Nm)	20	32	63	100	160
容許轉速 Admissible rpm nadm (rpm)	6000	5000	4000	4000	3200
傳動比 Gear ratio (i=n1/n2)	1.0	1.0	1.0	1.0	1.0/1.5
建議配置的動力馬達(IP67) Recommended tool drive motor (IP67)					
Siemens伺服馬達 Servo motor Type 1FK7..	..063	..084	..086	..103/ ..105	..108 1PH8107
Fanuc伺服馬達 α Servo motor	8/4000 is	12/4000 is	22/4000 is	40/4000 is	on request
Fanuc主軸馬達 α Spindle motor	1.5	2	3	6	8

軸向VDI刀盤-加工方式 Tooling for axial mount

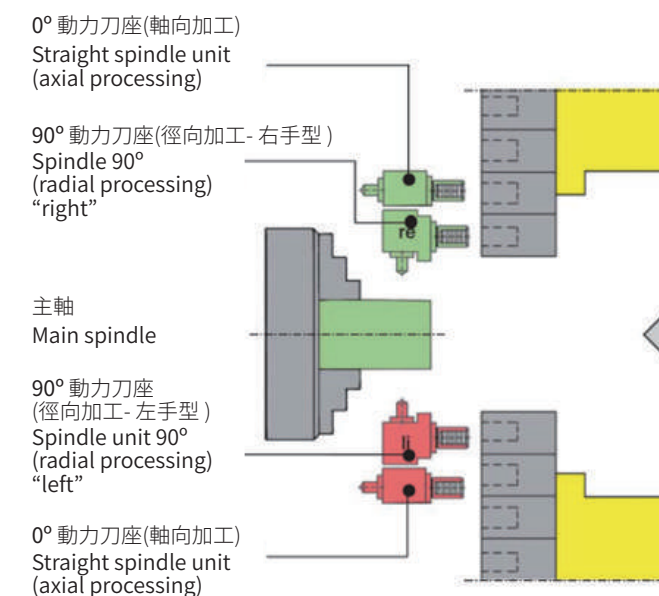

標準配置 Standard Configuration

機種 Type	規格 Specifications
436.212	436.212/8T/PCD200/VDI25/W3
	436.212/12T/PCD270/VDI30/W3
436.216	436.216/12T/PCD270/VDI30/W3
	436.216/12T/PCD300/VDI30/W3
	436.216/12T/PCD340/VDI40/W3
436.220	436.220/12T/PCD340/VDI30/W3
	436.220/12T/PCD340/VDI40/W3
	436.220/12T/PCD370/VDI40/W3
436.225	436.225/12T/PCD420/VDI50/W3
	436.225/16T/PCD480/VDI40/W3
436.232	436.232/8T/PCD447/VDI60/W3

刀座 Tool Holder

B2系列 Type		0度動力刀座 Driven tool holder-0 Degree	
B3系列 Type		90度動力刀座 Driven tool holder-90 Degree	
C2系列 Type		90度後縮動力刀座 Offset driven tool holder-90 Degree	
C3系列 Type		ER筒夾 Collet chuck	
搪孔刀座 Boring tool holder E2系列 type		套筒 Sleeve	



刀塔選型
Turret Product info



刀座型錄
Tool Holder

Servo Type Static Turret
440 伺服非動力刀塔

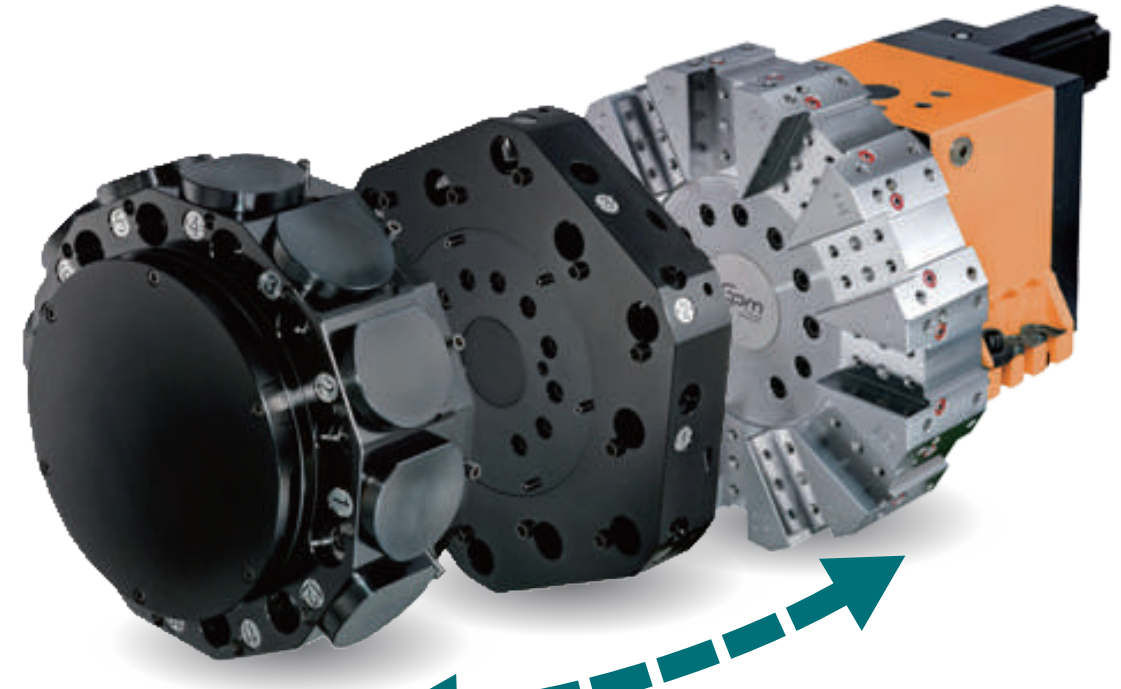
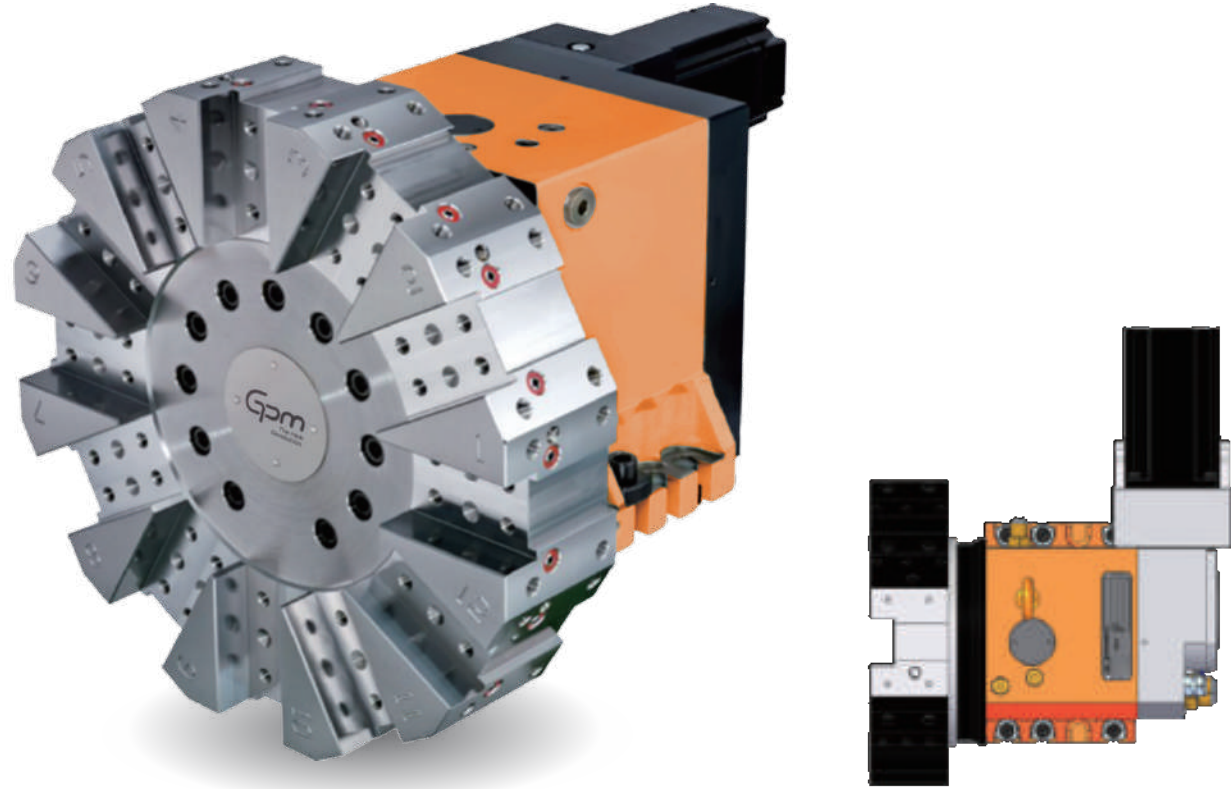

快速互換
Quick interchange

特色:

- 刀盤具互換性, 使用者可依不同需求選擇不同的刀盤, 當需求改變時只需更換刀盤不需要更換刀塔本體, 可有效降低庫存, 使用上更具彈性。
- 因應小型機床內部空間, 刀塔轉位馬達轉90度設計, 有效節省近40%長度。

Features:

- 440 series turrets may be mounted with slot type, VDI or BMT interface tool disc; Highly interchangeable and effectively reduce inventory pressure.
- Designed for small machines with limited space; nearly 40% of turret overall length is reduced when indexing motor turns 90 degree.

刀座
Tool Holder

H搪孔刀座組
Boring tool holder

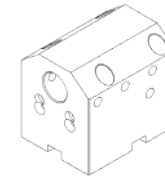

F端面刀座組
Facing tool holder

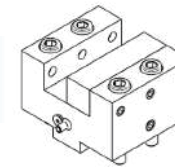

上&下壓板組
Clamping element

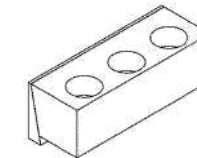

套筒
Sleeve



標準配置
Standard Configuration

機種 Type	規格 Specifications
440.212	440.212/SW220/8T/W3
440.216	440.216/SW270/8T/W3
	440.216/SW316/12T/W3
	440.216/SW330/8T/W3
440.220	440.220/SW380/8T/W3
	440.220/SW410/12T/W3
440.225	440.225/SW420/12T/W3
440.232	440.232/SW520/12T/W3



刀塔選型
Turret Product info



刀座型錄
Tool Holder

CONTENTS

P1-2	獨家刀塔產品特色 / 技術參數 Exclusive product features / Technical data
P3-4	440 伺服非動力刀塔 & 刀座 Servo Type Static Turret & Tool Holder
P5-6	436 VDI軸向動力刀塔 & 刀座 VDI Axial Mount Driven Turret & Tool Holder
P7-8	435 VDI徑向動力刀塔 & 刀座 VDI Radial Mount Driven Turret & Tool Holder
P9-10	434 BMT徑向動力刀塔 & 刀座 BMT Radial Mount Driven Turret & Tool Holder
P11	Y軸動力刀塔 Driven turret with Y axis
P12	客製化設計能力 ODM / OEM ability
P13	自動換刀刀塔 ATC Turret
P14	BMT動力刀塔 - 性能 智能 雙重升級 Double Upgrade- Performance & Intelligence
P15	其他特殊刀座 & 不同介面刀座 Other Special Tool Holder & various interfaces
P16	GPM 代理 As Agent for SAUTER
P17-18	公司發展歷程 Company Profile

Exclusive product features

獨家刀塔產品特色

全系列伺服刀塔皆內建三片齒與撞機跳脫T型塊

- 採用特殊設計高剛性三片齒，能提升鎖緊精度與切削剛性。
- 無論刀塔正反轉都能表現超高精度的定位、夾持力及穩定性。
- T型溝槽內建撞機跳脫T型塊，可緩衝撞車時產生的撞擊力，有效保護刀塔本體。
- 撞車發生時，不須特殊工具或專業技術人員，使用者即可自行更換或調整T型塊，迅速重現刀塔精度。
- 大幅提升維修效率，更能降低售服成本及停機時間。

Exclusive product features

- Whole series turrets are equipped with 3-part couplings and collision escape T-slot device.
- GPM adopts specially designed 3-part high rigid couplings to achieve high clamping precision and cutting rigidity.
- Collision escape T-slot device helps absorb impact force from crash to protect internal structure of turret.
- When a crash occurs, users could easily replace or adjust T-slot by themselves without requiring special tools or professional technicians to quickly restore the accuracy of the turret.



售服雲端化 Cloud Service

服務不受限，隨時可從雲端搜尋故障排除SOP。
Unlimited service: Trouble shooting SOP may be downloaded from the cloud anytime any where.

高壓出水方案 High pressure coolant

出水壓力 Coolant pressure	440	436	434	435
25 bar	標準 Standard			
70 bar	選配 Optional			
100 bar	Size 20/25/32	Size 20/25/32	Size 20/25	-

技術參數 Technical data

下表技術參數適用 440, 434, 435, 436 全系列GPM 自有品牌伺服刀塔
Applicable to 440, 434, 435, 436 series

項目 Item	單位 unit	尺寸與規格 Size & Specifications				
機型規格 (0./2./3.) Turret housing size		12	16	20	25	32
刀塔中心高 NH NH of turret housing	mm	63	80	100	125	160
鎖緊時容許切向力 Admissible tangential load (turret locked)	kNm	0.8	1.8	3.6	7.2	7.2
容許轉動慣量 Admissible mass moment of inertia of tools	kgm ²	1.2	2.5	5	12	40
容許加工過程的不平衡度 Admissible out of balance (load moment) due to tooling	i	16	32	63	125	200
轉位馬達齒輪比 Gear ratio of indexing motor	sec	45	54	72	90	216
分度時間 30° Rotate tool disc	sec	0.10-0.11	0.13-0.15	0.16-0.19	0.21-0.25	0.27-0.31
定位精度 Positioning accuracy	arcsec	±4"				
重覆定位精度 Repeating accuracy	arcsec	±1.6"				
最大負載重量 (刀盤+刀座) Max load (tool disc + tool holder)	kg	40	80	160	250	400
切削液壓力 Coolant pressure 標準 Standard 中等壓力 Medium pressure 高壓 High pressure	bar	5 - 25 (過濾精度 filter grade ≤ 100 μm) 25 - 70 (過濾精度 filter grade ≤ 50 μm) 70-150 (過濾精度 filter grade ≤ 25 μm)				
工作壓力 Operating hydraulic pressure	bar	50±5				
刀塔鬆開/鎖緊所需油量 Fluid absorption volume turret unlock/lock	cm ³	15	30	45	65	114

可配置之轉位馬達

Recommended indexing motor

馬達型號 (防水等級IP67以上) Item	J 質量	最高轉速	30°分度時間(不含加減速) swiveling time- without acceleration and braking				
motor type (IP67 or better)	kgm ²	max rpm	12	16	20	25	32
Delta A2-CA0807(EK700) 標配 standard	0.0003	4000	0.06	0.07	0.09	0.11	0.27
Siemens 1FK7042	0.0003	4500	0.05	0.06	0.08	0.1	0.24
Siemens 1FK7043 HD	0.0001	6000	0.04	0.05	0.06	0.08	0.18
Fanuc α2/5000 - β2/5000 - β4/4000	0.0003	4000	0.05	0.06	0.08	0.1	0.24

切削能力表 Cutting performance (non-binding reference values)

Series	Size						
Disk-type tool turret	10	12	16	20	25	32	
Drilling HSS spiral drill	d x s mmxmm /U	8 x 0.12	12 x 0.14	14 x 0.16	16 x 0.20	20 x 0.25	32 x 0.20
Drilling HM short hole drill	d x s mmxmm /U	12 x 0.05	15 x 0.08	16 x 0.10	20 x 0.12	24 x 0.16	32 x 0.16
Thread- drilling	d x P mmxmm /U	M 8 x 1	M 8 x 1.25 M 16 x 1	M10 x 1.5 M 24 x 1	M 14 x 2 M 20 x 1.5	M 18 x 2.5 M 36 x 1.5	M 20 x 2.5 M 42 x 2
Keyway axess cutting Finger milling	a x e x s mmxmm /U	1 x 5 x 45	12x8x45	16x12x40	20x12x40	22x25x40	30x20x40
Keyway cutting Disc cutting	a x e x s mmxmm /U	-	-	D = 50 8x8x45	D = 63 10x10x40	D = 80 18x18x40	D = 100 20x20x40

TURRET